

**Montageanleitung**  
**DORMA Schloss**  
**mit Drückerführung**  
*Studio Rondo*  
*Studio Classic*  
*ARCOS Studio*



**Glas Scholl**  
Inn. Dirk Lankemann  
Paul-Rücker-Str. 12 47059 Duisburg  
Mülheim 0208 / 58 90 000  
Duisburg **0203 / 99 30 60**  
Telefax 0203 / 99 306 33  
Internet [www.Glas-Scholl.de](http://www.Glas-Scholl.de)

24 Std

**Installation instructions**  
**DORMA lock**  
**with follower**  
*Studio Rondo*  
*Studio Classic*  
*ARCOS Studio*

**Wichtige Informationen:**  
**Important information:**

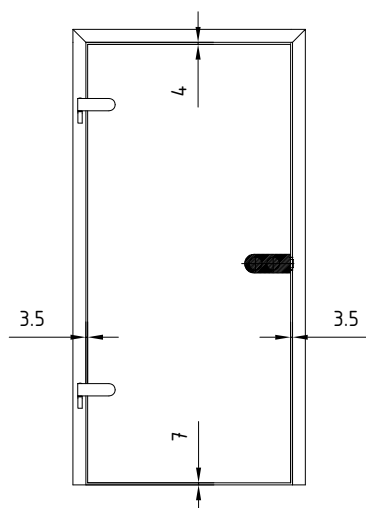

① = Bauteil/Baugruppe  
Component

1. ; 1.1 ; ... = Montagefolge  
Installation sequence

Vor der Montage Glasflächen mit handelsüblichem Glasreiniger im Bereich der Klemmflächen reinigen.

All glass clamping areas have to be cleaned with standard glass cleaning products prior to installation.



keine Verdünnung verwenden  
Do not use thinners

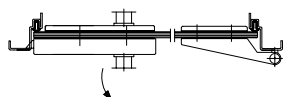

DIN rechts  
DIN RH

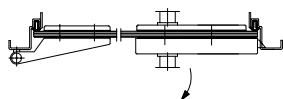

DIN links  
DIN LH

**Glasbearbeitung:**  
**Glass preparation:**

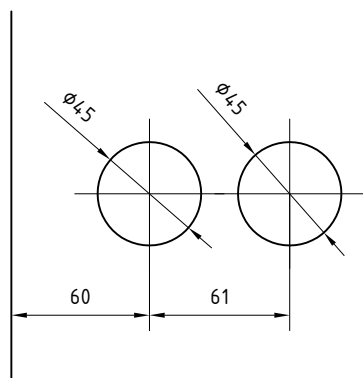

**Montagewerkzeug:**  
**Requisite tools:**

1,5 mm 3 mm 4 mm

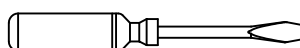
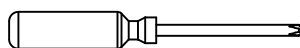

**Pflege allgemein:**

Die Oberflächen der Beschläge sind nicht wartungsfrei und sollten gemäß ihrer Ausführung gereinigt werden.

- Für metallische Oberflächen (Eloxaltöne, Edelstahl) bitte nur geeignete Reiniger ohne Scheuermittelanteil verwenden.
- Für lackierte Oberflächen bitte nur entsprechende lösemittelfreie Reiniger verwenden.
- Messing Oberflächen (ohne Oberflächenschutz) müssen von Zeit zu Zeit mit geeignetem Pflegemittel behandelt werden, um Anlaufen zu vermeiden.

**Wartung allgemein:**

Wir empfehlen die Funktion der Beschläge alle 200.000 Bewegungen, durch Fachleute, zu prüfen.

**General care instructions:**

The surface finishes of the fittings are not maintenance-free and should be cleaned according to their material and texture.

- For metallic surfaces (anodised finishes, stainless steel) please only use appropriate cleaning agents without abrasive additives.
- For varnished surfaces please only use appropriate solvent-free cleaning agents.
- To avoid tarnishing, brass surfaces (without surface protection) occasionally have to be treated with an appropriate care product.

**Service and maintenance:**

We recommend that such fittings be checked by specialists after every approx. 200,000 operations to conform their ongoing funktion integrity.

**Design Varianten:**  
**Design options:**



Darstellung mit Profilzylinder!  
Pictured with profile cylinder!

Studio Rondo

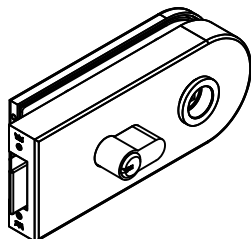

Studio Classic

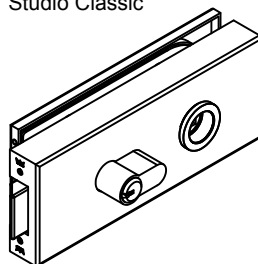

ARCOS Studio

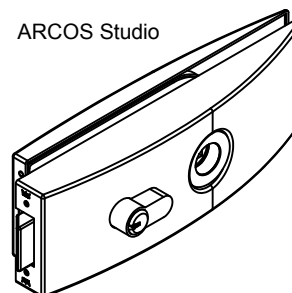

**Ausführungs Möglichkeiten:**  
**Application options:**



Die verschiedenen Ausführungsmöglichkeiten gibt es bei allen Design Varianten!  
All applications are available in all design options!



Darstellung: Studio Rondo  
Pictured: Studio Rondo

Verschließbar:  
Lockable:

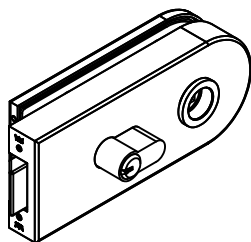

Schloss, PZ-vorgerichtet  
Lock, prepared for Europrofile cylinder

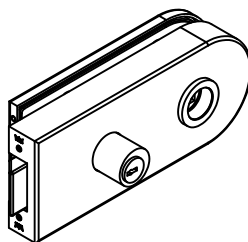

Schloss, Rundzylinder vorgerichtet  
Lock, prepared for round cylinder

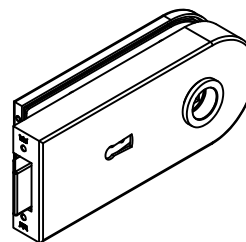

Schloss, mit Buntbart Schlüssel  
Lock, with warded key

Unverschließbar:  
Non-locking:

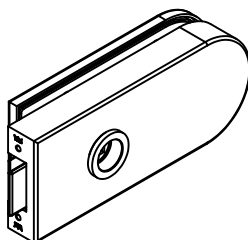
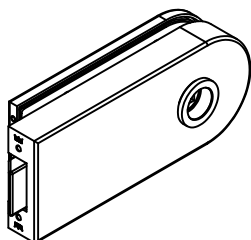

**Lieferumfang:**  
**Scope of delivery:**

Verpackungseinheiten sind bei allen aufgeführten Schlössern gleich!  
Pack contents identical for all listed lock types!

1,5 mm    4 mm

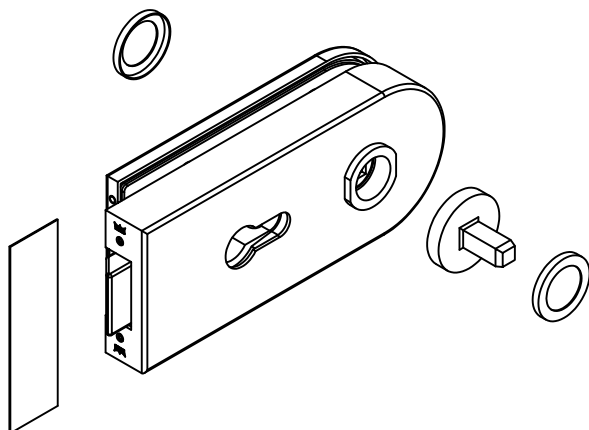

**1. Schritt:**  
**1. Step:**

Darstellung: Studio Rondo PZ-vorgerichtet  
Pictured: Studio Rondo prepared for Europrofile cylinder

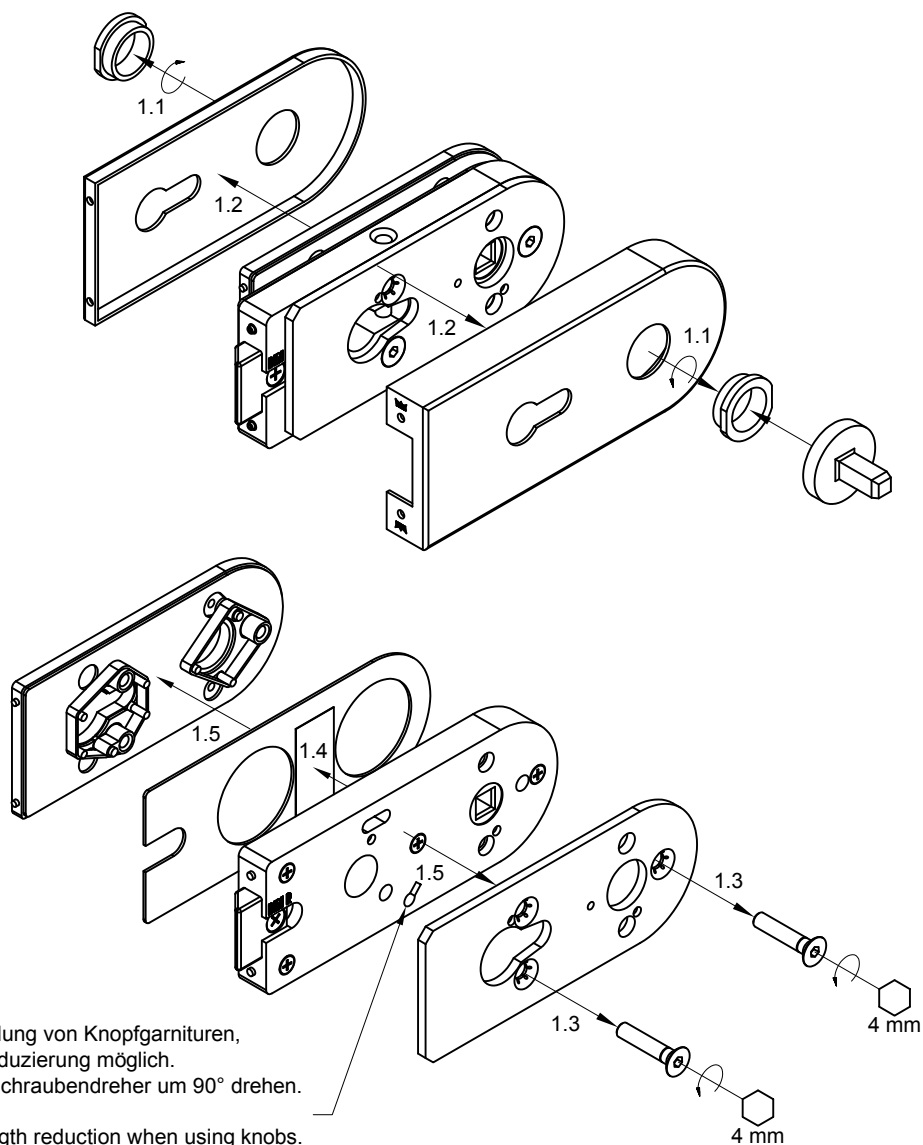

Bei Verwendung von Knopfgarnituren,  
Federkraftreduzierung möglich.  
Bolzen mit Schraubendreher um 90° drehen.

Spring-strength reduction when using knobs.  
Turn bolt with slotted screwdriver.

**2. Schritt:**  
**2. Step:**



Bitte auf die gewünschte DIN Richtung des Schlosses achten (siehe Detail X)!  
Please regard the desired DIN direction of lock (see detail X)!

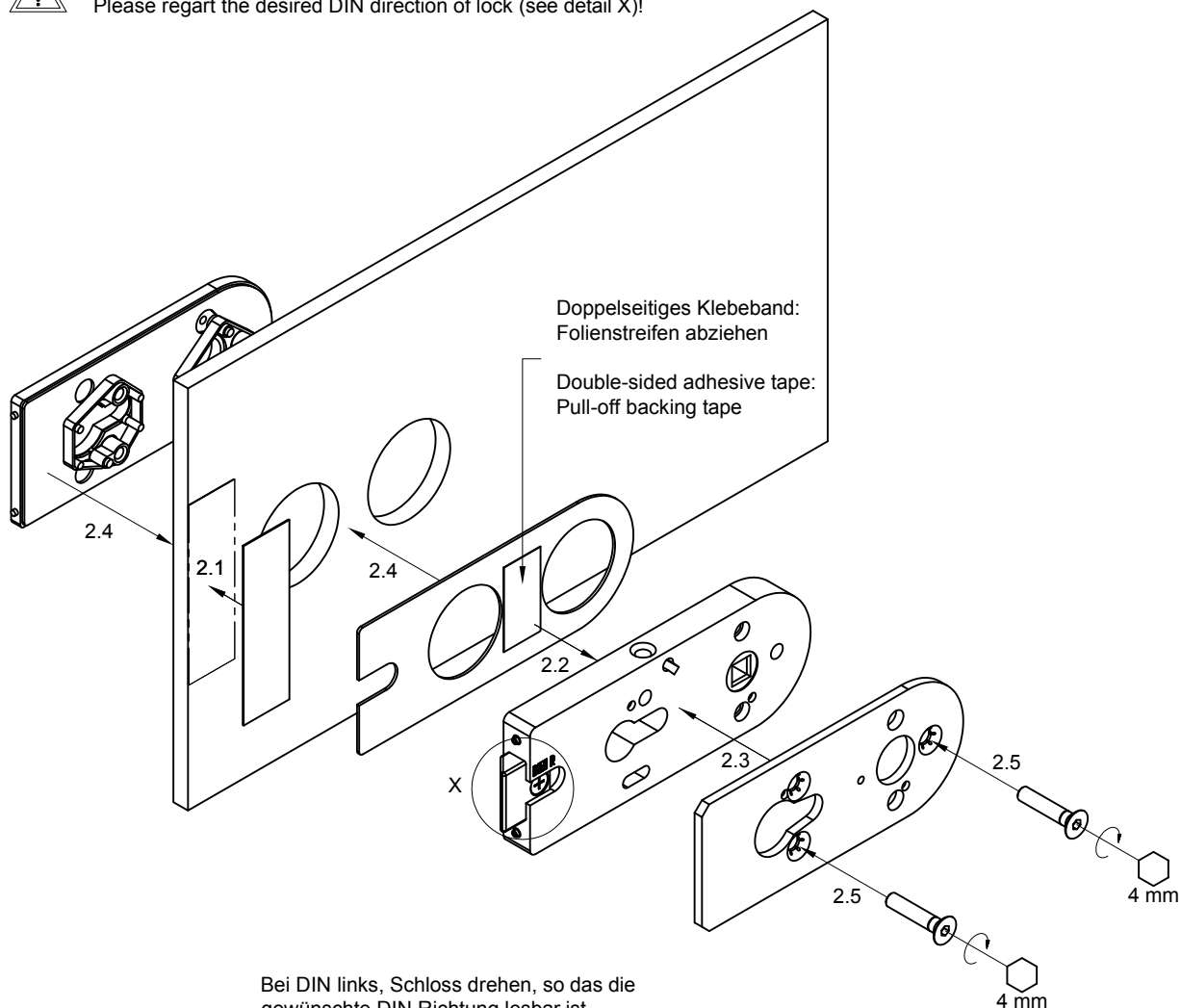

**DETAIL X**

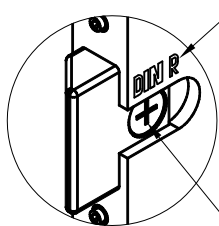

Bei DIN links, Schloss drehen, so das die gewünschte DIN Richtung lesbar ist.

By using of DIN LH, turn the lock, so that the desired DIN direction is legible.

Falle umdrehen. Die Schräge der Falle muss immer zum Glas zeigen!

Turn the latch. Bevelled side of latch must always point to the glass!

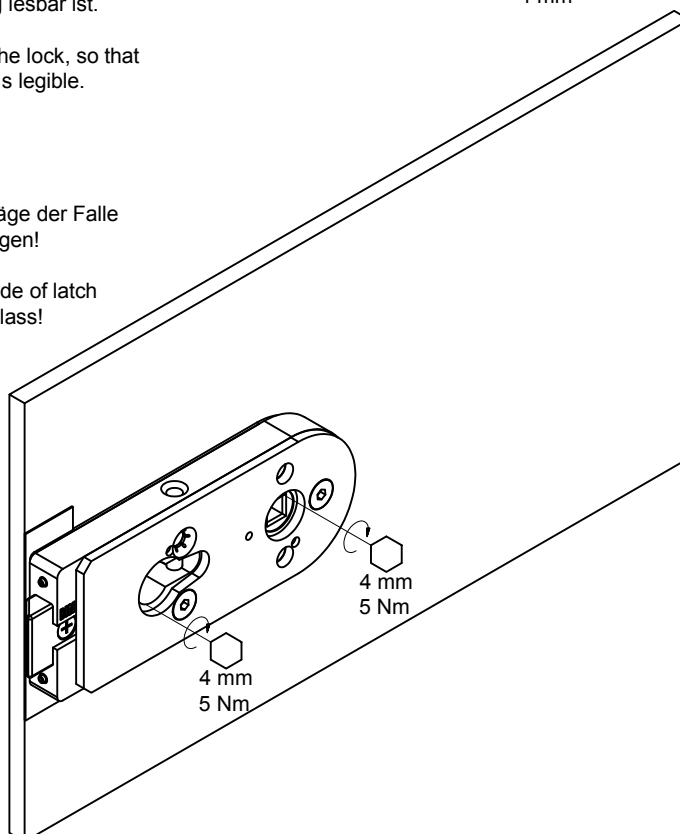
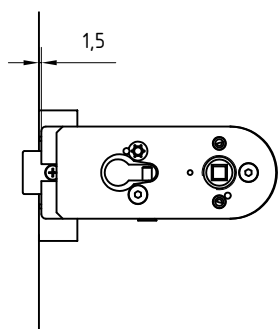

**3. Schritt:**

**3. Step:**



Profilzylinder und Schrauben sind nicht im Lieferumfang enthalten!

Profile cylinder and fixing screws are not included in scope supply!

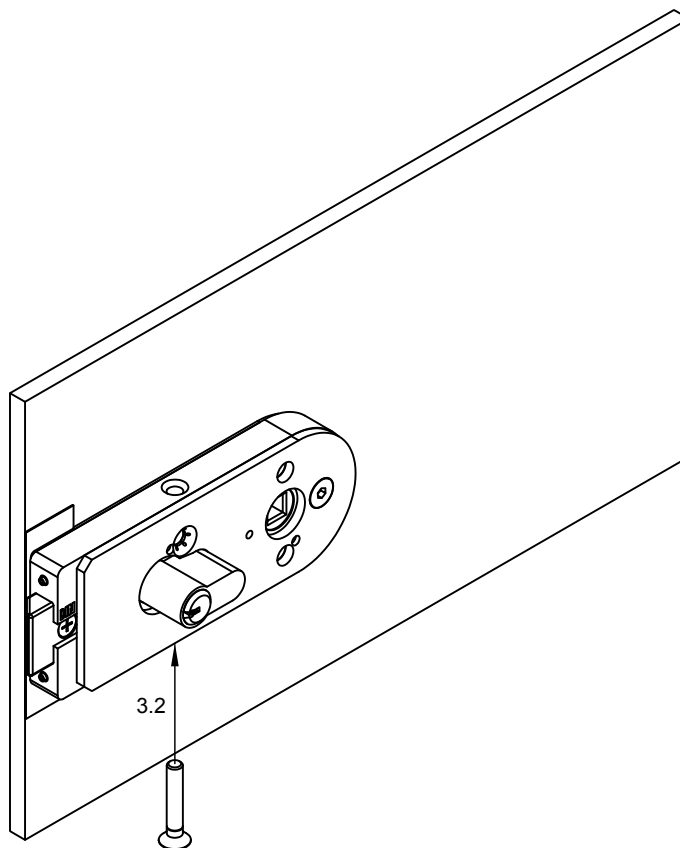
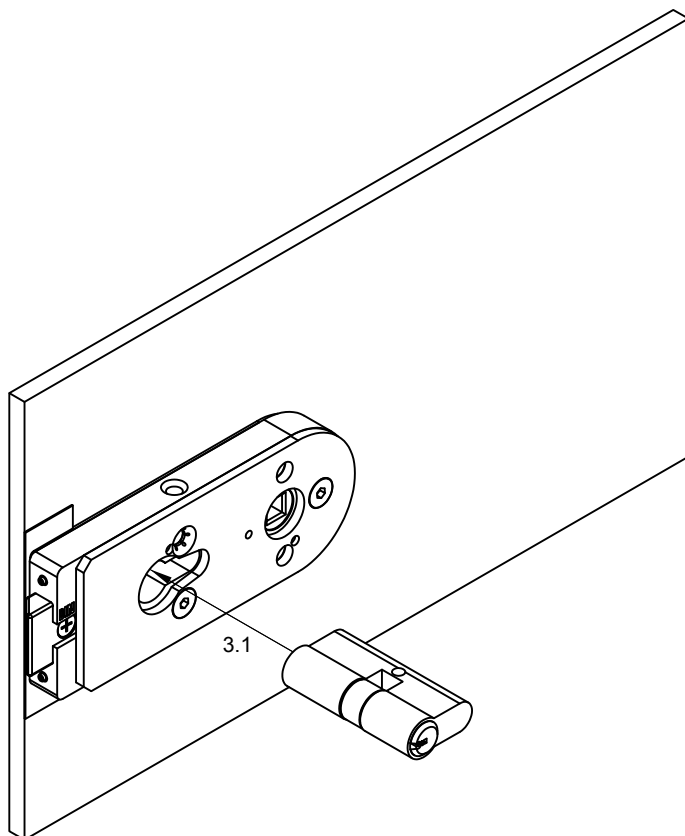

4. Schritt:  
4. Step:

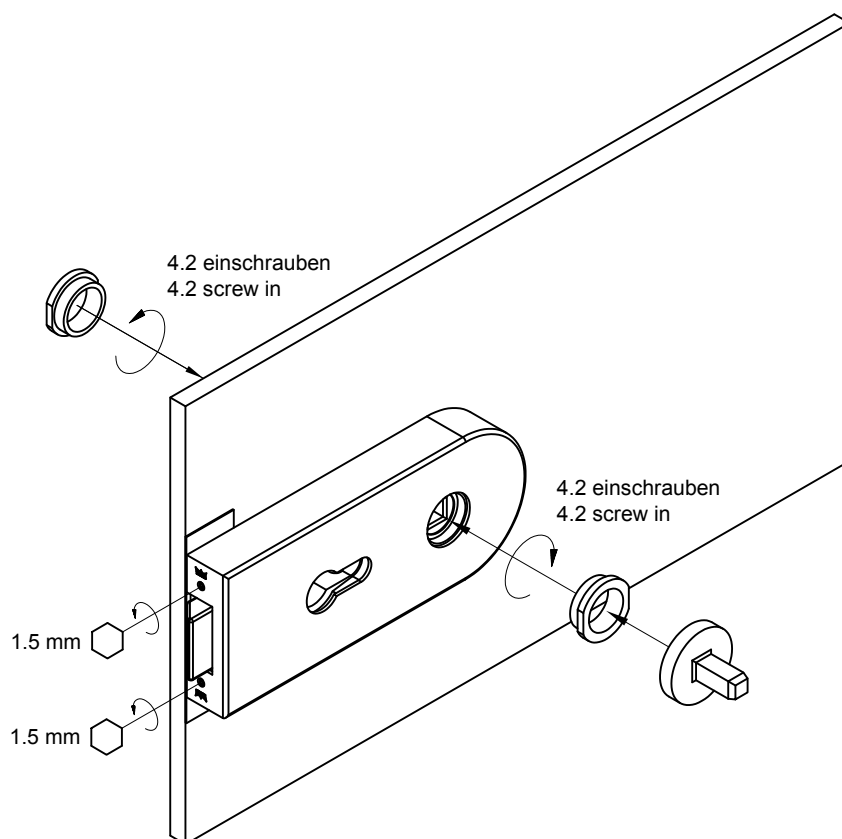
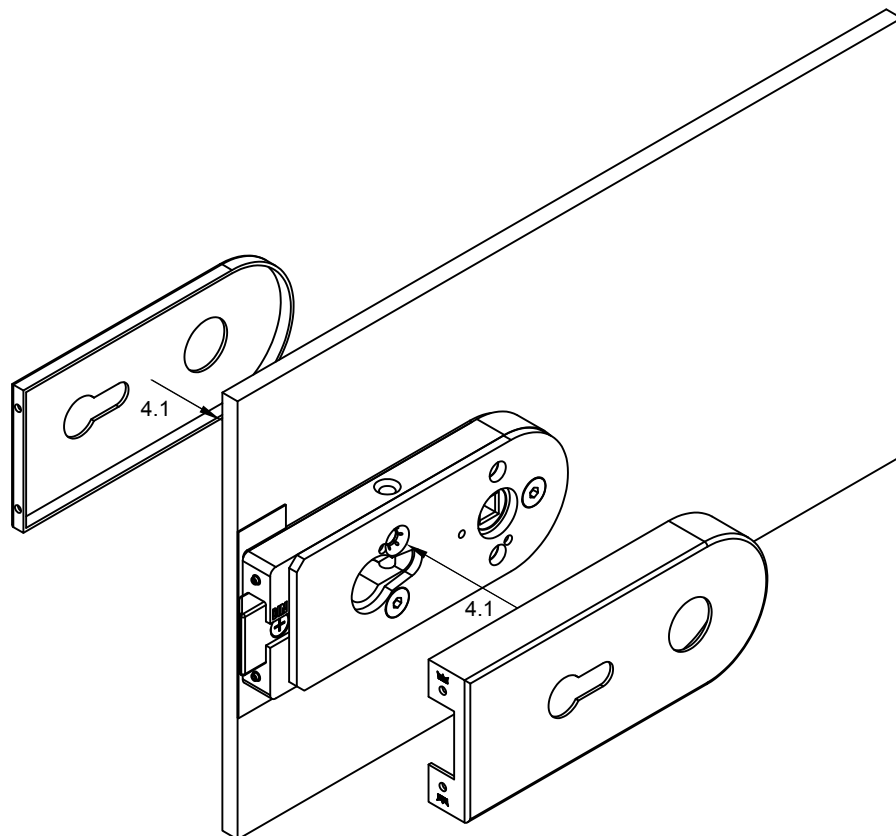

**5. Schritt:**

**5. Step:**



Drückergarnitur ist nicht im Lieferumfang enthalten!  
Lever handles are not included in scope of delivery!



Bei Verwendung sonstiger Drücker, siehe Montageanleitung Drückerhersteller!  
By use of other lever handles, please see installation instruction of manufacturer!

