

Montageanleitung DORMA RSP 80 Schiebetür an Wand

Mounting instruction DORMA RSP 80 Sliding door to wall

The logo for Glas Scholl, featuring a crest with a crown on top, a shield with a cross and a star, and the text "seit 1727" above it.

seit 1727

Glas Scholl

Inh. Dirk Lankemann

Paul-Rücker-Str. 12 47059 Duisburg
Mülheim 0208 / 58 90 000
Duisburg **0203 / 99 30 60**
Telefax 0203 / 99 306 33

Internet www.Glas-Scholl.de

A circular icon with a telephone handset and the text "24 Std" inside, indicating 24-hour service.

Wichtige Informationen:
Important information:

Vor der Montage Glasflächen
 mit handelsüblichem Glasreiniger
 im Bereich der Klemmflächen reinigen.

All glass clamping areas are to
 be cleaned with standard glass
 cleaning products prior to installation.



keine Verdünnung verwenden
 Do not use thinners

① = Bauteil/Baugruppe
 = Component

1. ; 1.1 ; ... = Montagefolge
 = Mounting sequence

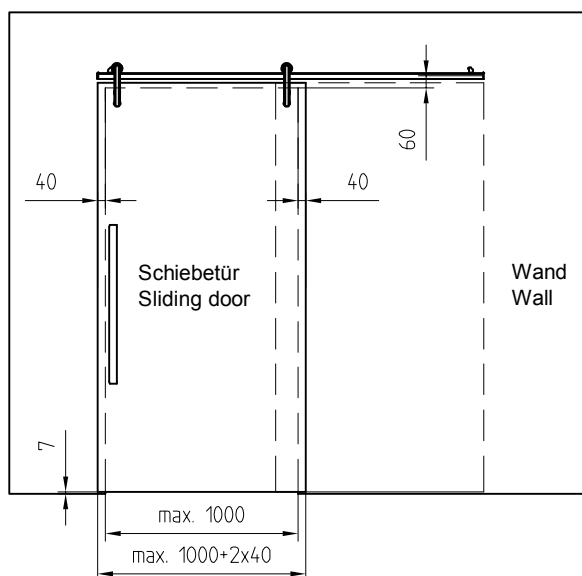

Detail Z

Glas Anbindung
 Glass connection

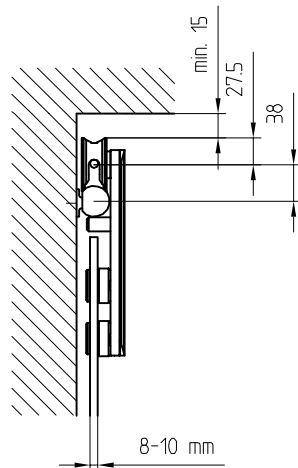
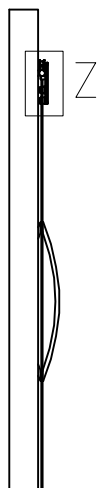

Detail Z

Holz Anbindung
 Wooden connection

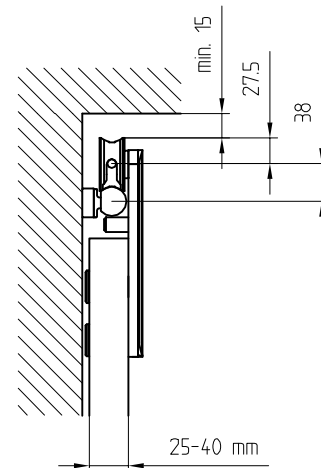

Glasbearbeitung:
Glass preparation:

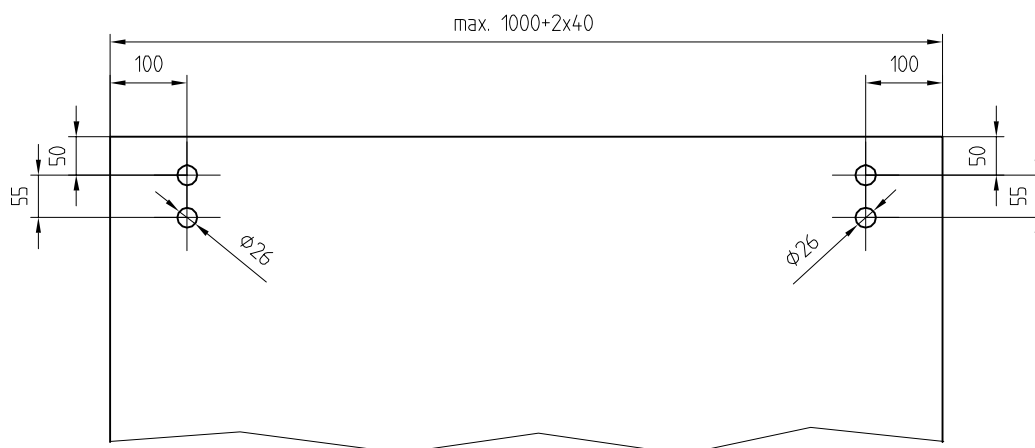



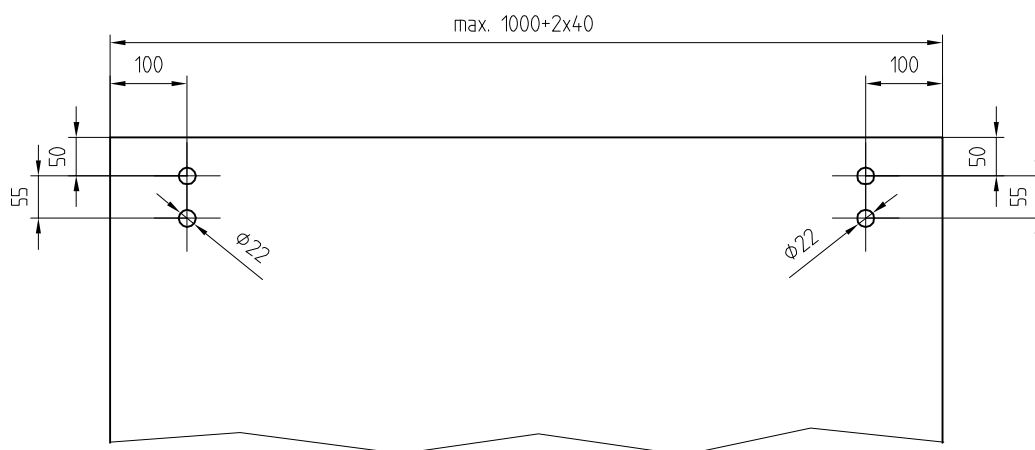

Holztürbearbeitung:
Wooden door preparation:

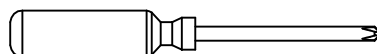
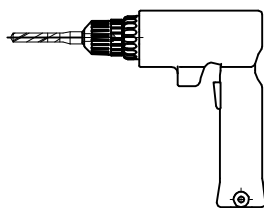

Montagewerkzeug:
Requisite tool:



-  2 mm
-  3 mm
-  4 mm
-  5 mm

Lieferumfang:
Scope of delivery:

Glas Anbindung
Glass connection

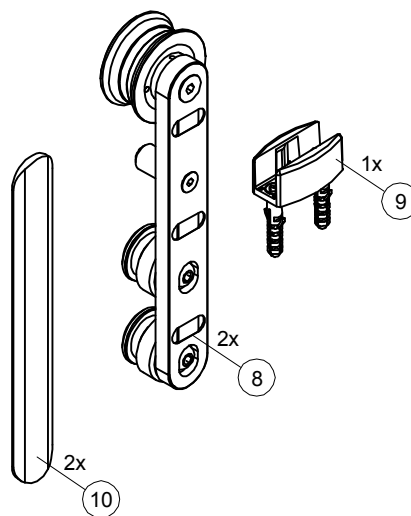
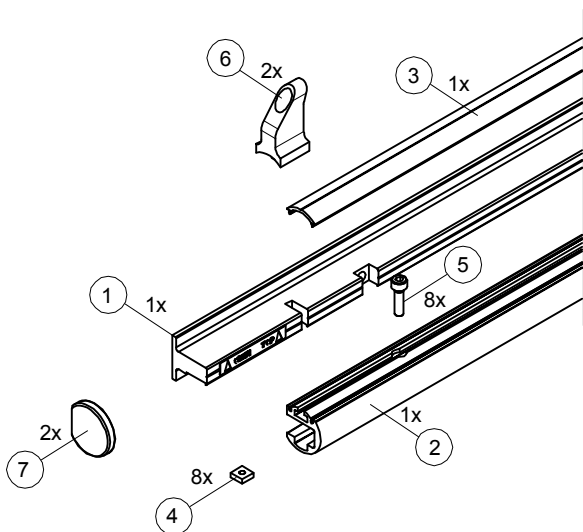

Schrauben und Dübel zur Wandbefestigung sind nicht im Lieferumfang enthalten!



Screws and wall plugs for wall connection are not included in delivery!

Holz Anbindung
Wooden connection

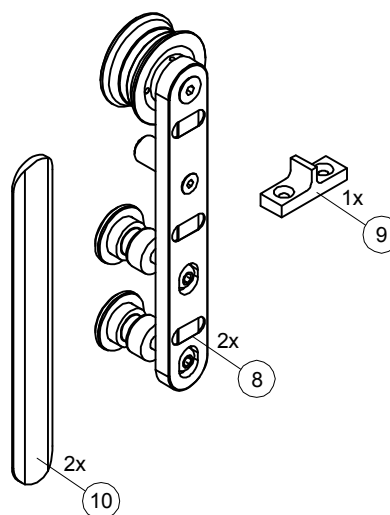
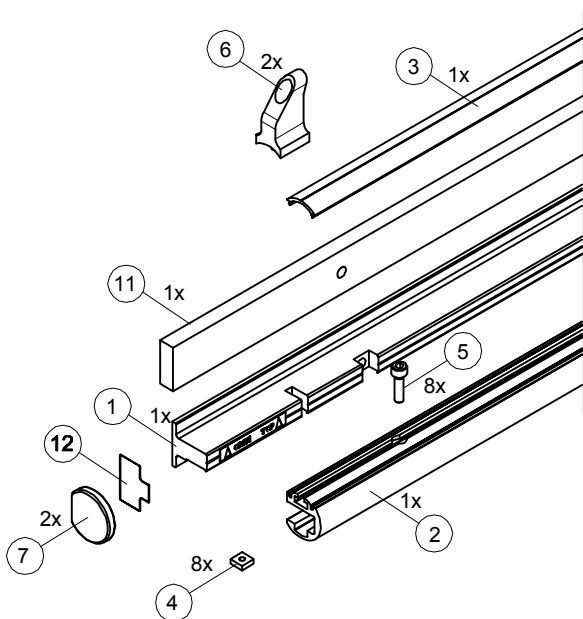

Schrauben und Dübel zur Wandbefestigung sind nicht im Lieferumfang enthalten!



Screws and wall plugs for wall connection are not included in delivery!

Lieferumfang:
Scope of delivery:



1. T-Profil an Wand schrauben:
1. Mounting of T-profile onto wall:

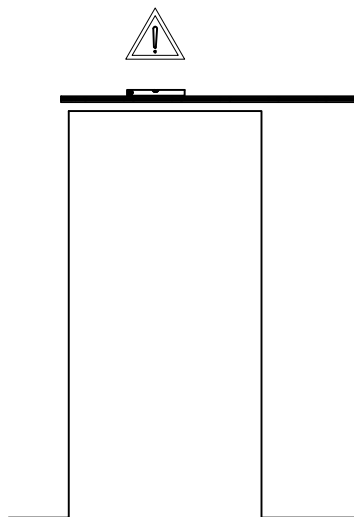

Schrauben und Dübel zur Wandbefestigung sind nicht im Lieferumfang enthalten!



Screws and plugs for wall connection are not included in delivery!

Glas Anbindung
Glass connection

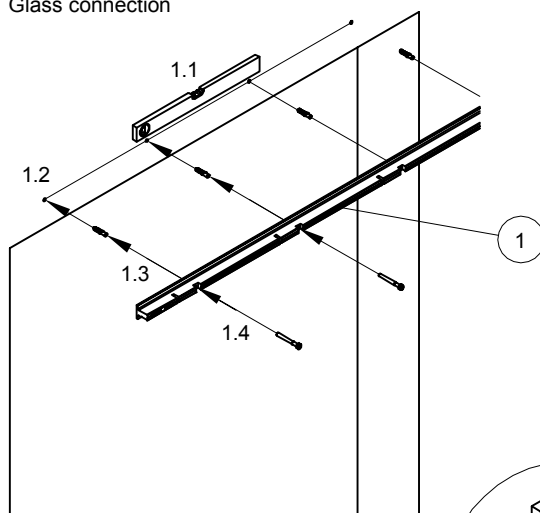

Holz Anbindung
Wooden connection

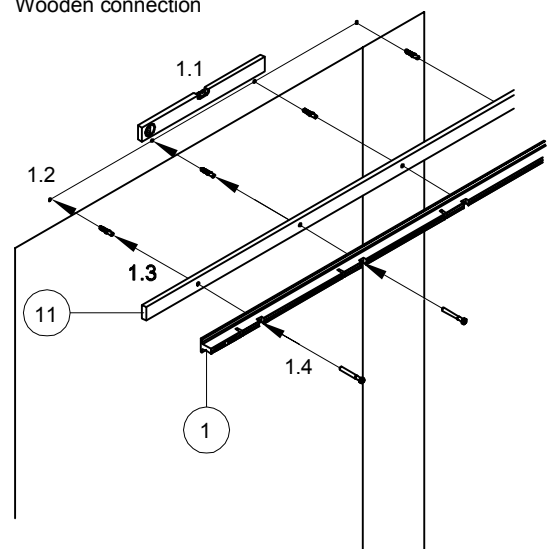

Aussparung nach unten
Recess facing downwards

**2. Vorbereitung des Laufschienenprofils:
2. Preparing of the track rail profil:**

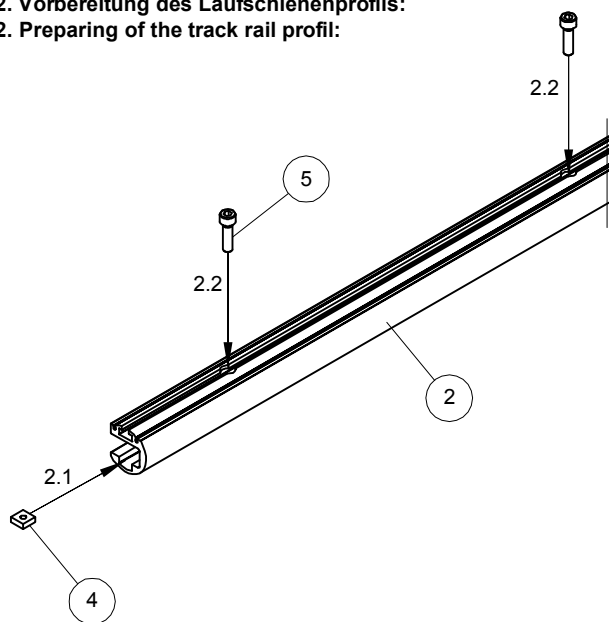

2.2 Schrauben ein Gewindegang in Nutsteine schrauben!
2.2 Tighten screws one convolution in slot nuts!

**3. Laufschiene auf T-Profil verschrauben:
3. Mounting of track profile on T-profile:**

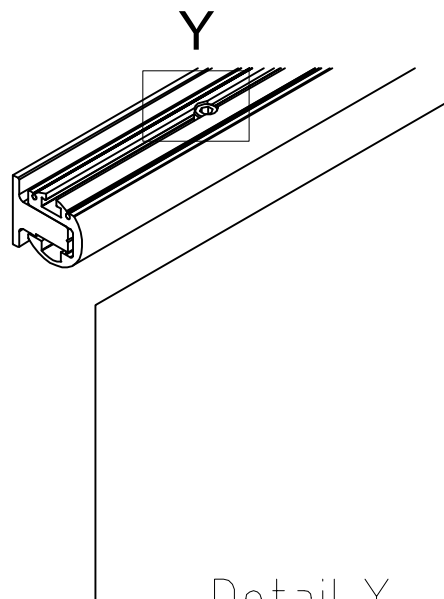
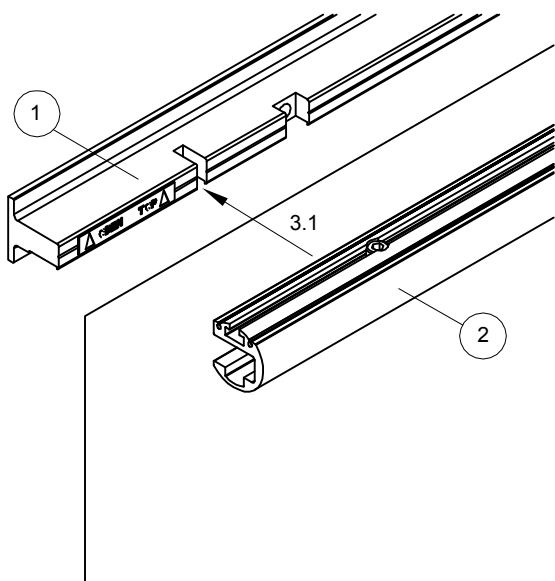

Detail Y

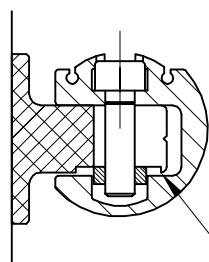

Aussparung nach unten
Recess facing downwards

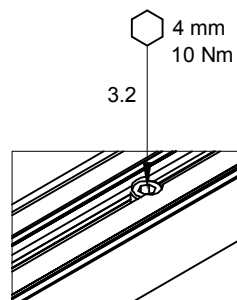

4. Rollprofil auf Laufschiene klippen:
4. Roll-profile connect to track rail:

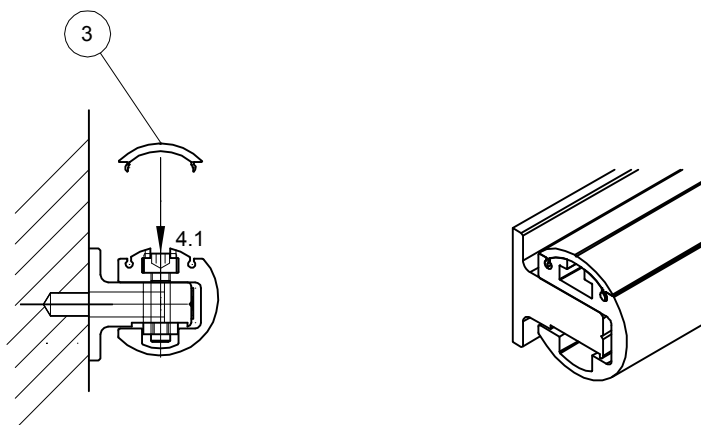

5. Vorbereitung Rollenwagen:
5. Preparing the track rail:

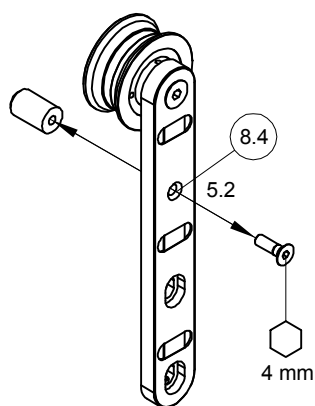
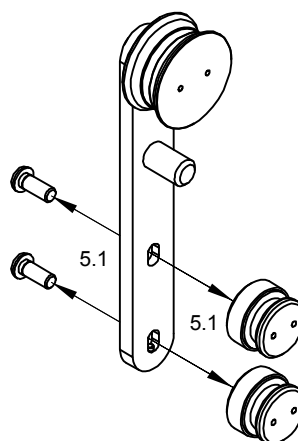
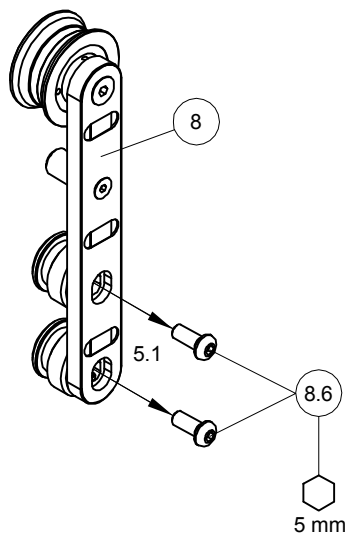

6. Montage Rollenwagen an Glas:
6. Mounting roller on glass:

6.3 Aufstecken und leicht anschrauben
 6.3 Attach and tighten easily

Glas Anbindung
 Glass connection

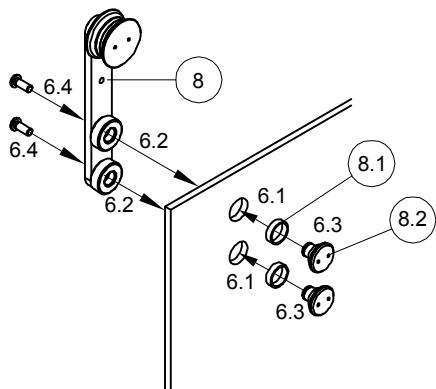

Holz Anbindung
 Wooden connection

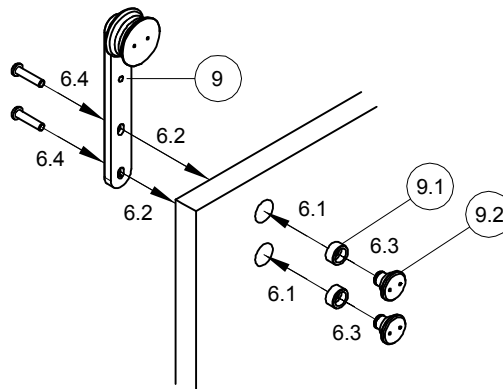

7. Bodenführung montieren:
7. Mounting of the floor guide:

7.1 Schiebetür einhängen und Bodenführung (9/10) markieren
 7.1 Fit sliding door and mark the floor guide (9/10)

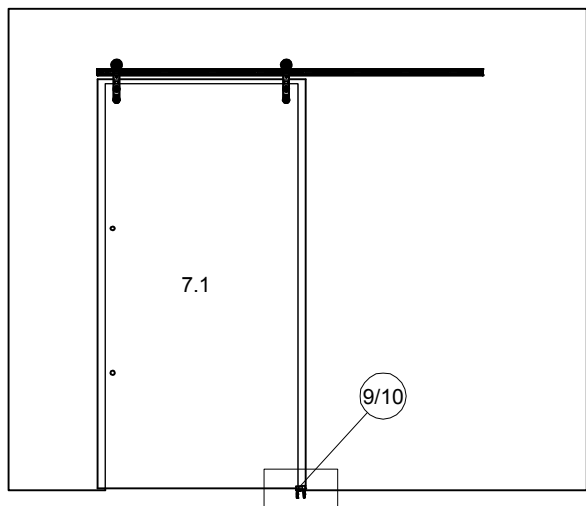

Glas Anbindung
 Glass connection

Ansicht von oben
 Top view

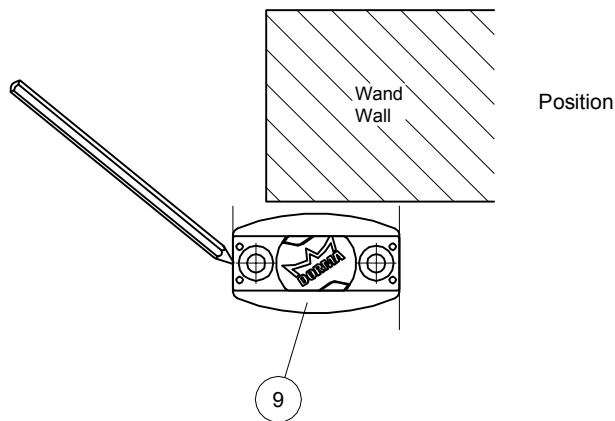

Holz Anbindung
 Wooden connection

Ansicht von oben
 Top view

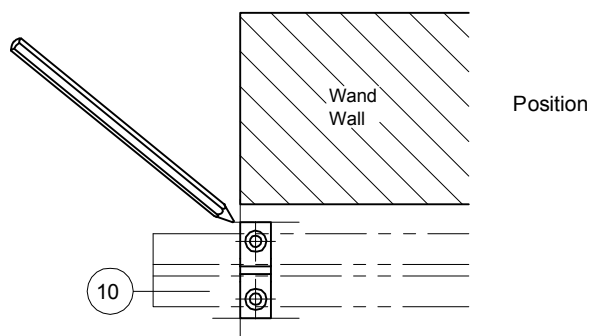

7. Bodenführung montieren:
7. Mounting of the floor guide:

7.2 Schiebetür aushängen und Bohrungen makieren
 7.2 Lift out sliding door and mark the holes

Detail W

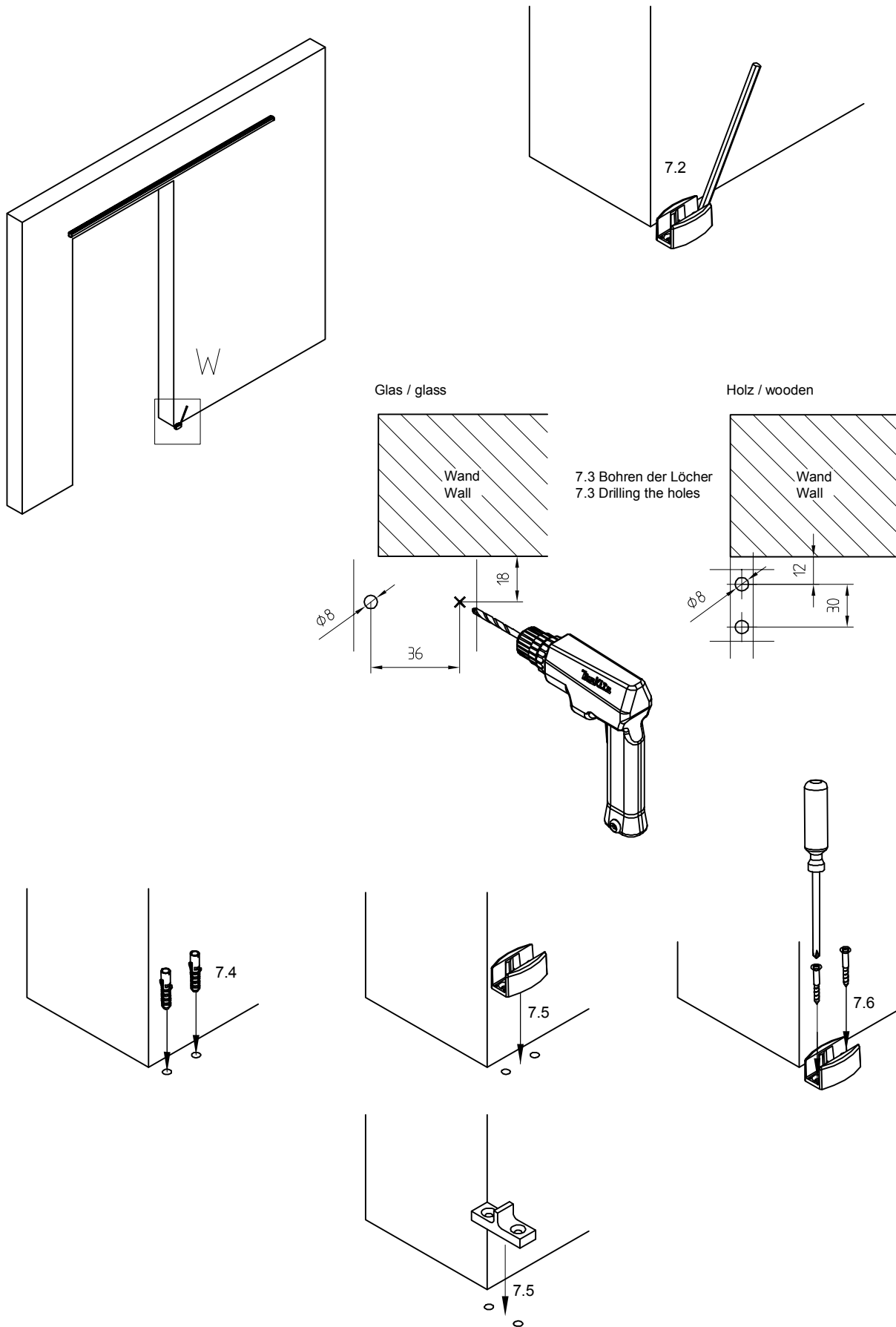

8. Türstopper montieren:
8. Mounting of the door stoppers:

8.1 Schiebetür einhängen
 8.1 Fit sliding door

8.2 Tür vollständig schließen
 8.2 Close the door completely

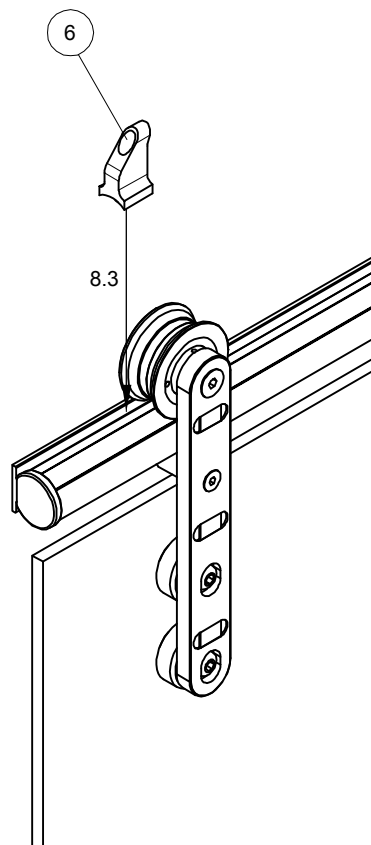
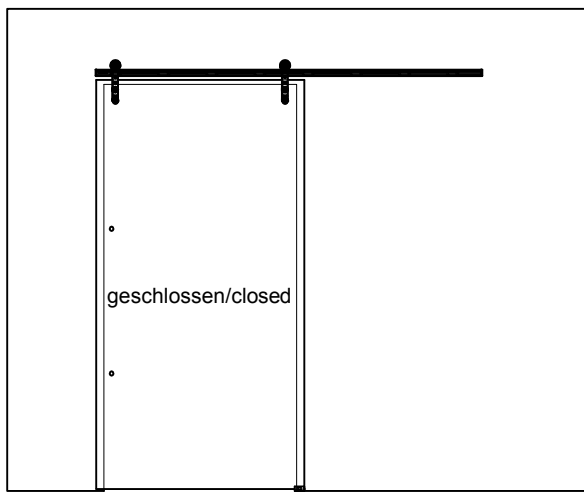

8.4 Tür vollständig öffnen
 8.4 Open the door completely

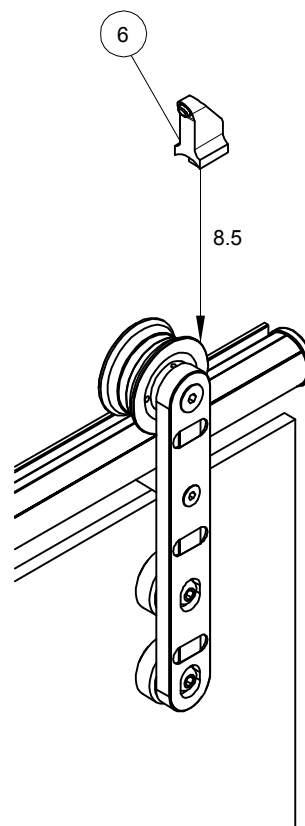
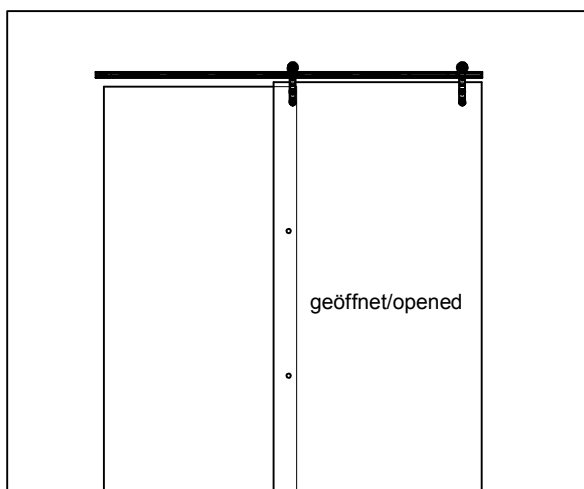

8. Türstopper montieren:
8. Mounting of the door stoppers:

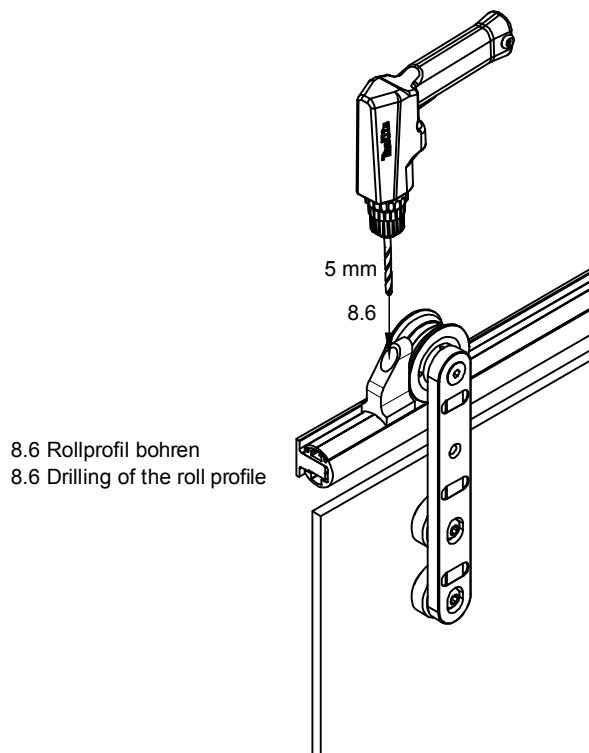

Nur das Kunststoffprofil bohren.
Only drill the plastic profile.

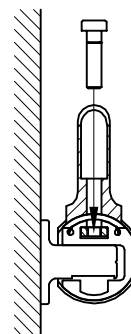
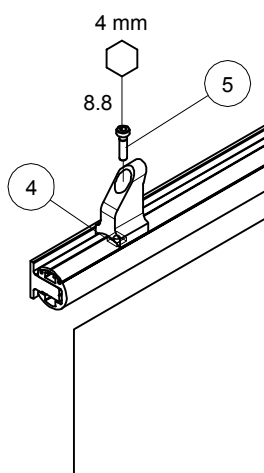
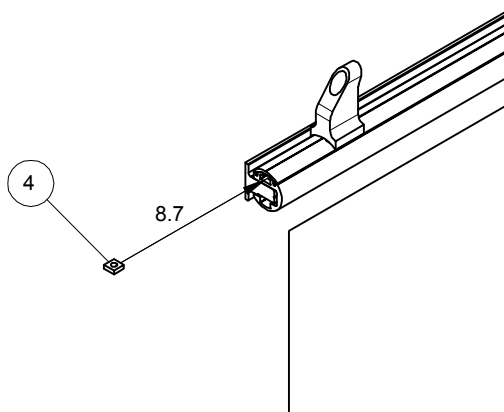

9. Abdeckkappen befestigen:

9. Fasten of the cover caps:

9.0 Folienstreifen abziehen und Dekofolie (12) aufkleben

9.0 Pull off backing tape and glue on the decoration strip (12)

9.1 Folienstreifen (7.1) abziehen und Kappen (7) aufkleben

9.1 Pull off backing tape (7.1) and stick on the cover caps (7) into right place

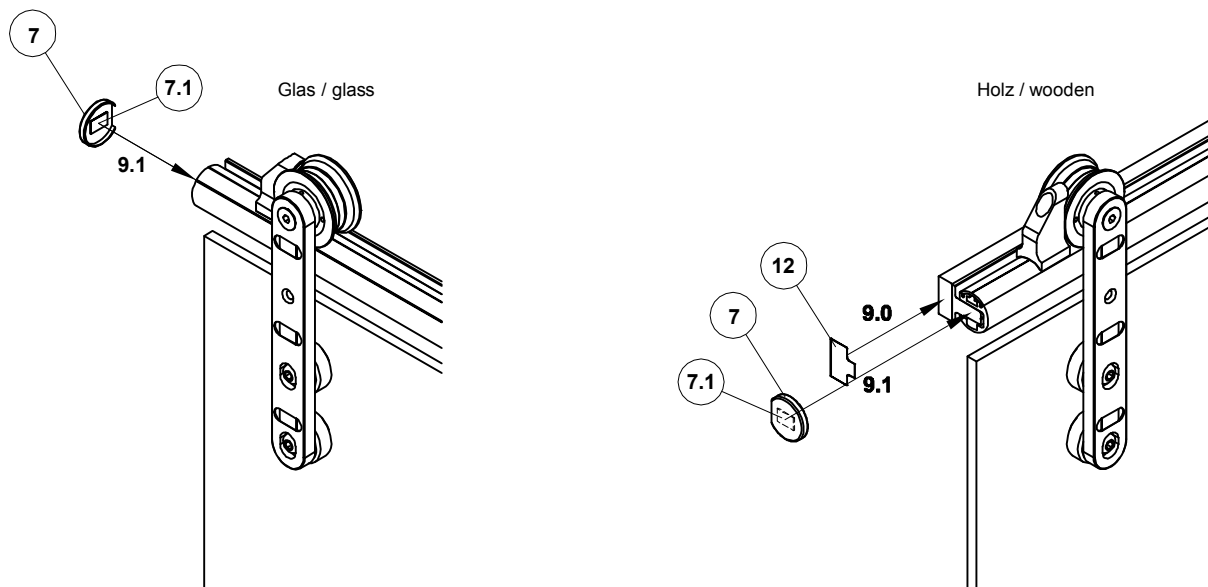

10. Aushebeschutz montieren:

10. Mounting of the antijump mechanism:

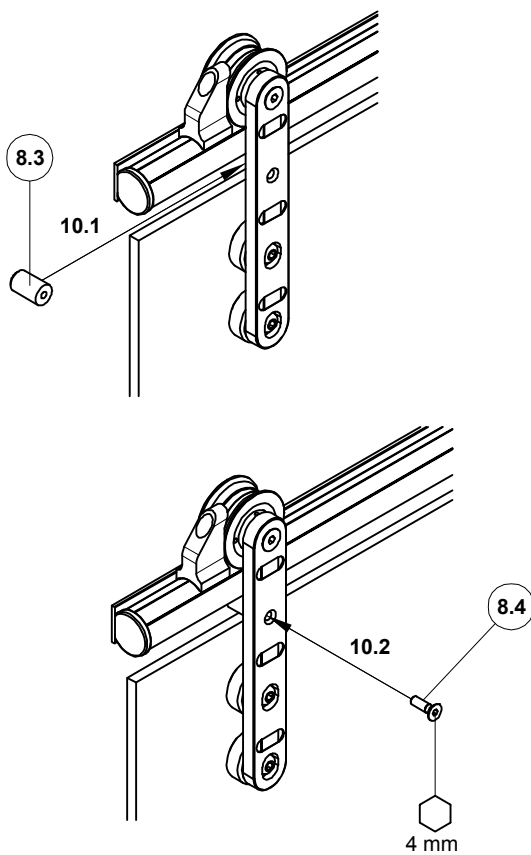

**11. Tür einstellen:
11. Adjusting of the door:**

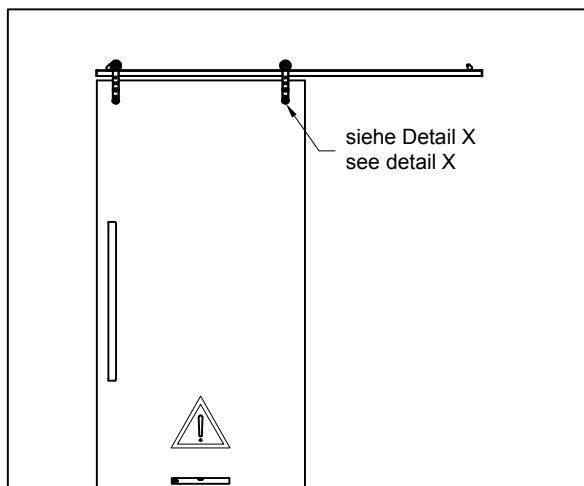

Detail X

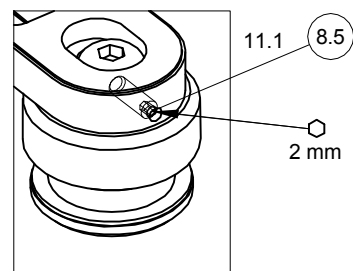

11.1 Justieren der Punkthalter mit Hilfe des Gewindestifts

11.1 Adjust the single-point fixings via the setscrew

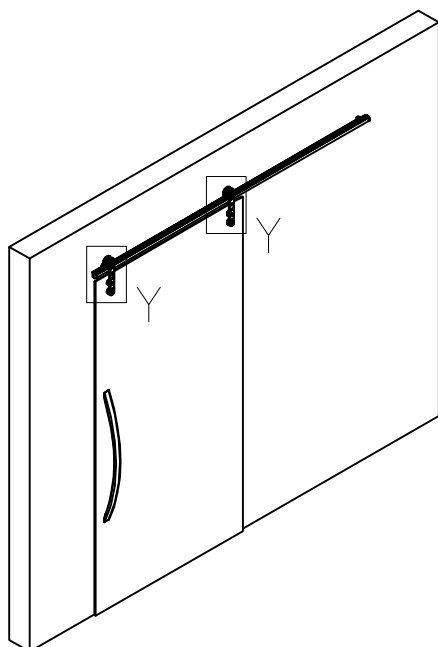

Detail Y

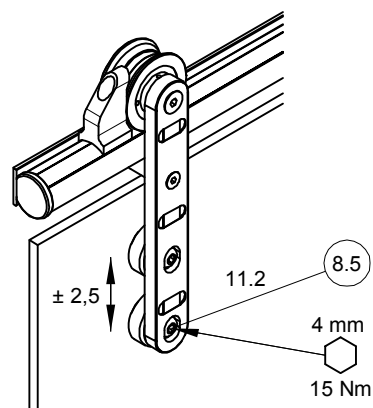

**12. Abdeckkappen auf Rollenwagen montieren:
12. Mounting of the cover caps on roller:**

12.1 Folienstreifen (8.6) abziehen und Kappen (10) aufkleben

12.1 Pull off backing tape (8.6) and stick on the cover caps (10) into right place

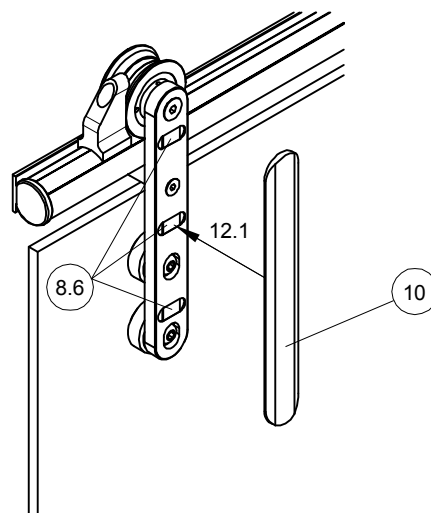

seit 1727 **Glas Scholl**
 Inh. Dirk Lankemann
 Paul-Rücker-Str. 12 47059 Duisburg
 Mülheim 0208 / 58 90 000
 Duisburg 0203 / 99 30 60
 Telefax 0203 / 99 306 33
 Internet www.Glas-Scholl.de